

 **Infinity**[®]

kappa series
10.3t tweeter
instructions

Thank you for purchasing Infinity's Kappa 10.3t automotive tweeter. We've organized this manual to make your installation as simple and trouble-free as possible. Please read it thoroughly before proceeding. Remember to keep your sales receipt with this manual in a safe place so both are available for future reference.

INSTALLATION WARNINGS AND TIPS

ABOUT THESE INSTRUCTIONS

Installation of automotive stereo components can require extensive experience with a variety of mechanical and electrical procedures.

Although these instructions explain how to install Kappa 10.3t tweeters in a general sense, they do not show the exact installation methods for your particular vehicle. If you feel you do not have the experience, do not attempt the installation yourself but, instead, ask your authorized Infinity car audio dealer about professional installation options.

LOUD MUSIC AND HEARING

Playing loud music in an automobile can permanently damage your hearing, as well as hinder your ability to hear traffic. The maximum volume levels achievable with Infinity speakers, combined with high power amplification, may exceed safe levels for extended listening. We recommend using low volume levels when driving. Infinity accepts no liability for hearing loss, bodily injury, or property damage as a result of use or misuse of this product.

ABOUT THE CROSSOVER

Passive crossover design involves precise circuit design and component selection. Moreover, a well-designed crossover circuit provides an intended electrical response, when combined with the electrical properties of the speaker, to provide a particular acoustic response. Each enclosed crossover has been optimized to provide a flat response when used with a Kappa 10.3t tweeter.

Do not use another brand or type of passive crossover, or connect more than one tweeter to a crossover. Doing so may damage the tweeter.

INSTALLATION TIPS

- Always wear protective eyewear when using any tools.
- Turn off all audio components and other electrical devices before you start. Disconnect the negative (-) lead from your vehicle's battery.
- Keep speakers in their package until final installation. When moving a speaker, always rest it with the cone or dome facing up. Never use force to install any speaker.
- Check clearances on both sides of a planned mounting surface before drilling any holes or installing any screws. Remember that the screws can extend behind the surface.
- At the installation sites, locate and make a note of all fuel lines, hydraulic brake lines, vacuum lines and electrical wiring. Use extreme caution when cutting or drilling in and around these areas.
- Before drilling or cutting holes, use a utility knife to remove unwanted fabric or vinyl to keep material from snagging in a drill bit or saw.
- For door installations, check the clearance with the windows throughout the range of the window's travel, and verify that a mounted speaker will not interfere with the window crank or power-window mechanism.
- If mounting speakers elsewhere, check for clearance around rear-deck torsion bars, glove box or other structural elements.
- Do not mount speakers where they will get wet.

SPEAKER PLACEMENT

ABOUT PLACEMENT

Figures 1 and 2 show possible speaker placements with Figure 1 being more desirable. We recommend using the kick panel for mounting to obtain the best staging and imaging in most vehicles.

Figure 1. Mounting the woofer and tweeter in the kick panel.

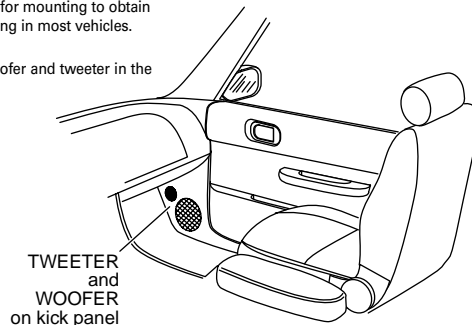
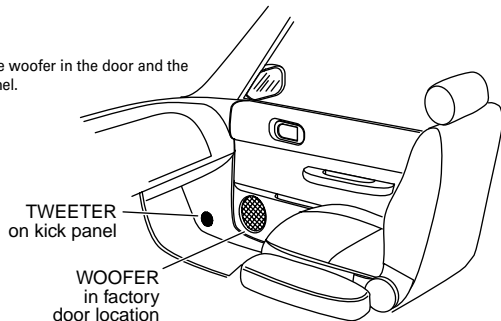

Figure 2. Mounting the woofer in the door and the tweeter in the kick panel.



TWEETER INSTALLATION

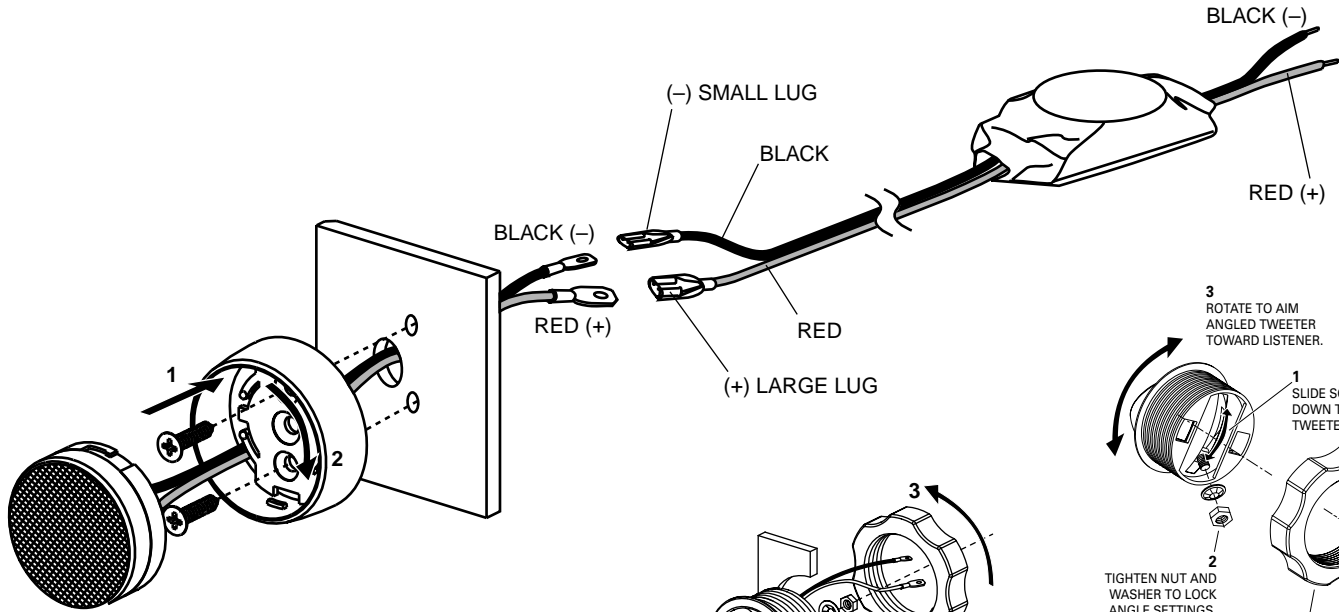

Figure 3. Surface-mounting the tweeter and connecting the crossover.

Figure 4. Mounting the tweeter using the I-Mount™ (patent no. 5,859,917) flush-mounting kit. Also see Figure 5.

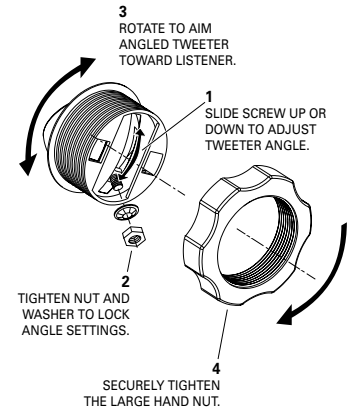
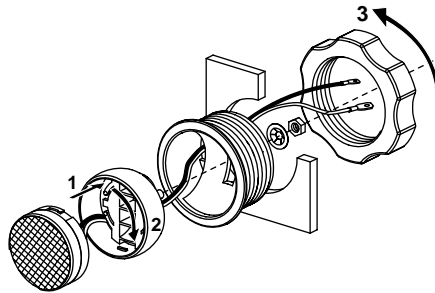

Figure 5. Aiming the tweeter at a desired listening position.

SPECIFICATIONS

10.3t

Type: 1" tweeter
Speaker Impedance: 4 ohms
Power Handling: 50W RMS, 150W Peak
(with enclosed crossover)
Sensitivity (2.83V, 1m): 90dB
Frequency Response: 3.5kHz – 21kHz
Mounting Depth: 1-3/16" (31mm)
Cut-out Diameter: 1-7/8" (47mm)

GENERAL CARE

The loudspeaker grilles may be cleaned with a damp cloth. Do not use any cleaners or solvents on the grilles or the speaker cones.



Infinity Systems, Inc., 250 Crossways Park Drive, Woodbury, NY 11797 USA
(800) 553-3332 • FAX (516) 682-3523 • www.infinitysystems.com
© 2001 Infinity Systems, Inc. • P/N: KAP10.3tOM • Printed 3/01
H A Harman International Company

DECLARATION OF CONFORMITY



We, Harman Consumer International
2, route de Tours
72500 Chateau-du-Loir
France

declare in own responsibility, that the product described in this owner's manual is in compliance with technical standards:
EN 50081-1:1992
EN 50082-1:1992

A handwritten signature in black ink, appearing to read "Lutz Uphoff".

Lutz Uphoff
Harman Consumer International
Chateau-du-Loir, France 3/01